



trameu

MACHINES AND
EQUIPMENTS
FOR WIRE AND
CABLES INDUSTRY



LES MO MACHINERY AMERICA, INC
sales@lesmoamerica.com www.lesmoamerica.com

SOMMER GROUP



PUNZONATRICI PORTATILI

Una gamma completa di punzonatrici a batteria, elettriche o azionate da centralina idraulica. Tutte le macchine sono a "Doppio Effetto" (DE) per una agevole estrazione del punzone senza inceppamenti.

Punzonatrice a batteria PG 22/60 DE
cod. **1.50.2395**



HANDHELD PUNCHING TOOLS

A complete range of battery, electrical and pump operated punching machines. All the tools are "Double Acting" (DE) for an effective jam-free punch retraction.

PG 22/60 DE cordless punching machine
cod. **1.50.2395**

PUNZONATRICE	PUNCHING MACHINE	PG 22/60 DE 1.50.2395
Tensione	Voltage	18V/2,0Ah
Potenza	Power	12 ton
Foro max	Hole max	22mm
Spessore	Thickness	5mm
Pressione	Pressure	550 bar
Peso con batteria al Litio	Weight including Lithium ion battery	14,2kg

Punzonatrice a batteria PG 22/120N DE
cod. **1.50.2507**
Profondità incavo 120mm



PG 22/120N DE cordless punching machine
cod. **1.50.2507**
120mm throat

PUNZONATRICE	PUNCHING MACHINE	PG 22/120N DE 1.50.2507
Tensione	Voltage	18V/2,0Ah
Potenza	Power	12 ton
Foro max	Hole max	30mm*
Spessore	Thickness	5mm
Pressione	Pressure	550 bar
Peso con batteria al Litio	Weight including Lithium ion battery	14,7kg

Punzonatrice a batteria PB500 DE
cod. **1.50.2399**



PB500 DE cordless punching machine
cod. **1.50.2399**

PUNZONATRICE	PUNCHING MACHINE	PB500 DE 1.50.2399
Tensione	Voltage	18V/2,0Ah
Potenza	Power	21 ton
Foro max	Hole max	30mm
Spessore	Thickness	12mm
Pressione	Pressure	550 bar
Peso con batteria al Litio	Weight including Lithium ion battery	14,7kg



Tutte le macchine sono dotate di appoggio regolabile e estrattori Punzoni quadrati e ovali disponibili su richiesta. Tutte le macchine a batteria hanno una batteria al litio in dotazione. Per batterie supplementari, carica batteria ed altri accessori vedi pag. 32 - 33

All the tools are equipped with adjustable support and strippers. Squared and oval punches available. All cordless tools are supplied with one lithium ion battery. For spare batteries, charger and other accessories see page 32 - 33



PUNCHING TOOLS

PUNZONATRICI

Punzonatrice PZN 28 DE matrice sporgente
cod. **1.50.1972**

Ideale per profili metallici a T - L
Optional: base d'appoggio cod. 1.50.2291



PZN 28 DE punching machine raised die
cod. **1.50.1972**

Suitable for T - L metal profiles
Optional: stand cod. 1.50.2291

PUNZONATRICE PUNCHING MACHINE PZN 28 DE 1.50.1972

Tensione	Voltage	230V/50Hz
Potenza	Power	28 ton
Foro max	Hole max	30mm
Spessore	Thickness	10mm
Pressione	Pressure	25kg
Peso	Weight	550 bar

Punzonatrice PZN 28 DE
cod. **1.50.1963**

Matrice piana
ideale per punzonare
putrelle e travi.



PZN 28 DE punching machine
cod. **1.50.1963**

Flat die, ideal for punching joists and beams.

PUNZONATRICE PUNCHING MACHINE PZN 28 DE 1.50.1963

Tensione	Voltage	230V/50Hz
Potenza	Power	28 ton
Foro max	Hole max	30mm
Spessore	Thickness	10mm
Pressione	Pressure	25,4kg
Peso	Weight including	550 bar

Testa punzonatrice
DE PZ 28/65 DE
cod. **1.50.694**

Da abbinare
a corpo cesoia MU26DE
cod. **1.50.149**

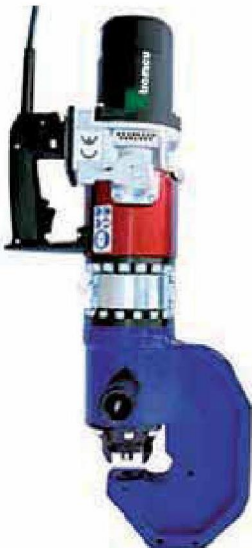

PZ 28/65 DE punching head DE
cod. **1.50.694**

Matches tool body MU26DE cod. **1.50.149**

PUNZONATRICE PUNCHING MACHINE PZ 28/65 DE 1.50.694

Tensione	Voltage	230V/50Hz
Potenza	Power	40 ton
Foro max	Hole max	22mm
Spessore	Thickness	10mm
Pressione	Pressure	700 bar
Peso	Weight	34kg

PUNZONATRICI IDRAULICHE

HYDRAULIC PUNCHING

Punzonatrice a doppio effetto

Double acting punching machine

P35/110 DE cod. **1.50.653**
 PZ C35/150 DE cod. **1.55.057**

P35/110 DE cod. **1.50.653**
 PZ C35/150 DE cod. **1.55.057**

Azionamento con centralina idraulica per impieghi pesanti

Pump operated for heavy-duty applications



PUNZONATRICE	PUNCHING MACHINE	P35/110 DE 1.50.653	PZ C35/150 DE 1.55.057
Tensione	Voltage	230V/50Hz	230V/50Hz
Tensione	Voltage	440V/50Hz	440V/50Hz
Polenza	Power	44 Iou	80 Iou
Foro max	Hole max	30mm	35mm
Spessore	Thickness	10mm	16mm
Peso	Weight	55kg	145kg
Pressione	Pressure	700 bar	700 bar

PUNCHING TOOLS

PUNZONATRICI

DIMENSIONI DELLE TESTE DI PUNZONATURA

PUNCHING HEADS DIMENSIONS

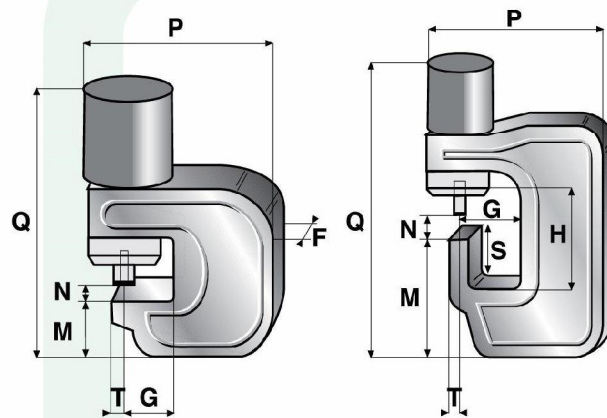

	MISURE IN MM					SIZES (MM)				
	F	G	H	M	N	P	Q	S	T	
PG 22/60 DE	40	70	/	109	15	178	217	43	25	
PG 22/120 DE	40	120	/	96	15	250	204	/	27,5	
PB 500 DE	53	50	/	111	16	172	216	52	22,5	
PZ 28/65 HEAD	60	65	/	100	20	200	173	/	28,5	
PZN 28 DE COD. 1.50.1963	65	59	/	89	16	180	230	/	29	
PZN 28 DE COD. 1.50.1972	65	57	/	143	12	195	280	52	24,5	
P 35/110 DE	100	110	/	110	25	342	265	/	34,5	
PZ C35/150 DE	120	150	/	173	35	410	415	/	35	

WORLDWIDE SALES NETWORK



in North America

LESMO MACHINERY AMERICA, INC

329 Rayette Rd, # 13-14
Concord, Ontario
L4K 2G1
Canada

Tel: + (905) 761-6165
Fax: + (905) 761-6168
sales@lesmoamerica.com
www.lesmoamerica.com



Tramev s.r.l.
Via Pascoli, 47
23861 Cesana Brianza (LC) - Italy
Phone +39 031658511
Fax +39 031658496
Mail: info@tramev.com
www.tramev.com
Skype: tramevsrl
Follow us on 